

NBT560-15

Ceiling Mounts



NBT560-15 is a ceiling mount for LCD and LED flat panel TV. Designed for high end projectors suitable for commercial and home used. Constructed and made out of high tensile steel, rigid and stable with adjustable height to suit your requirements.

Adjustable system

■ Product incorporate with high tech adjustable system providing hung free at any required points without fine tune. Easy and convenience.

Golden adjustment angles

■ Certified -5 and +15 degrees adjustment range provides ergonomic to your viewing angles and height adjustment level and avoid being tired when watching your programmed

Easy to install

■ Modular system designed to save you installation time.

Flat Panel Tilt mount

- Fits most 32"-57" flat panel TV
- VESA compliance : 100x100mm
100x200mm, 200x200mm, 200x400mm
300x300mm, 400x400mm, 400x600mm
- Load capacity : 150lbs (68.2kg)
- Tilt angle : -5°/+15°
- Swivel : -30°/+30°
- Color : Black
- Material : SPCC with coating finished

Product Features

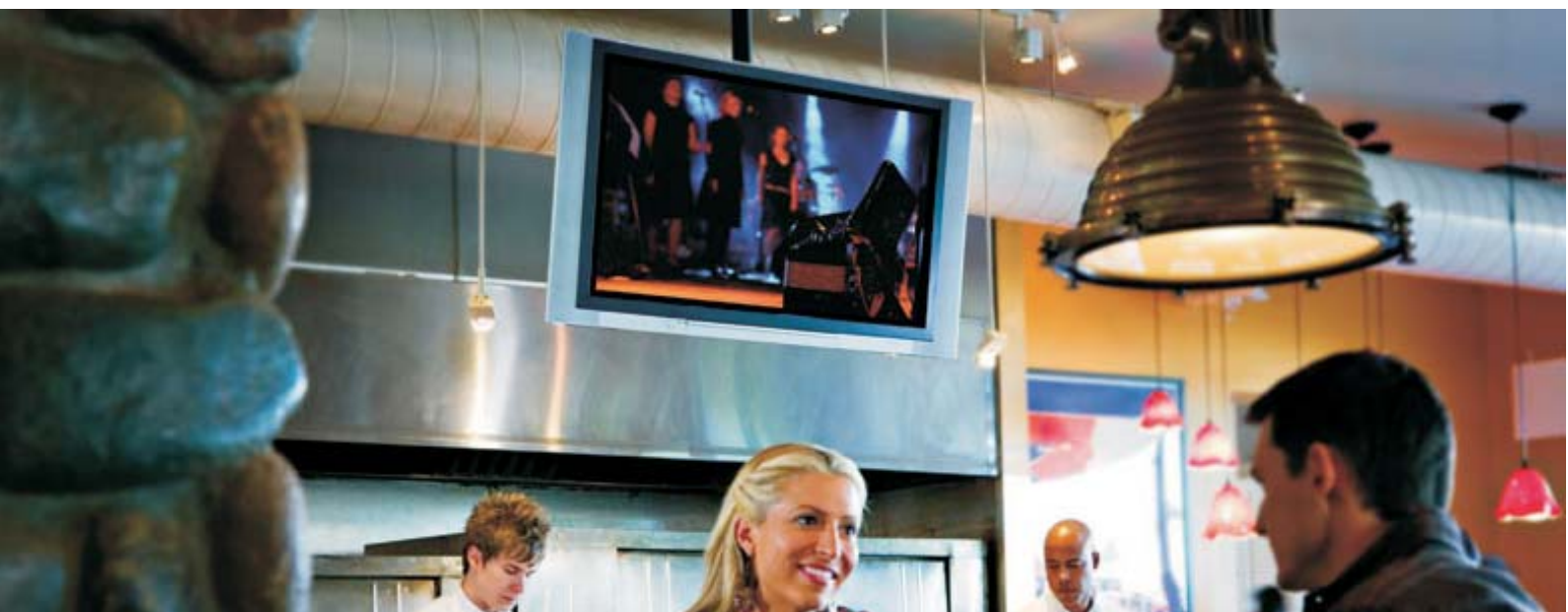
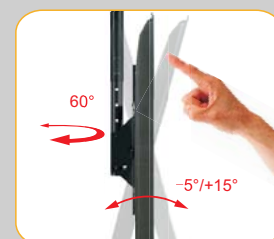
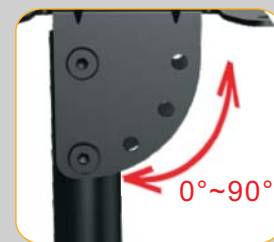

NBT560-15 Ceiling Mounts

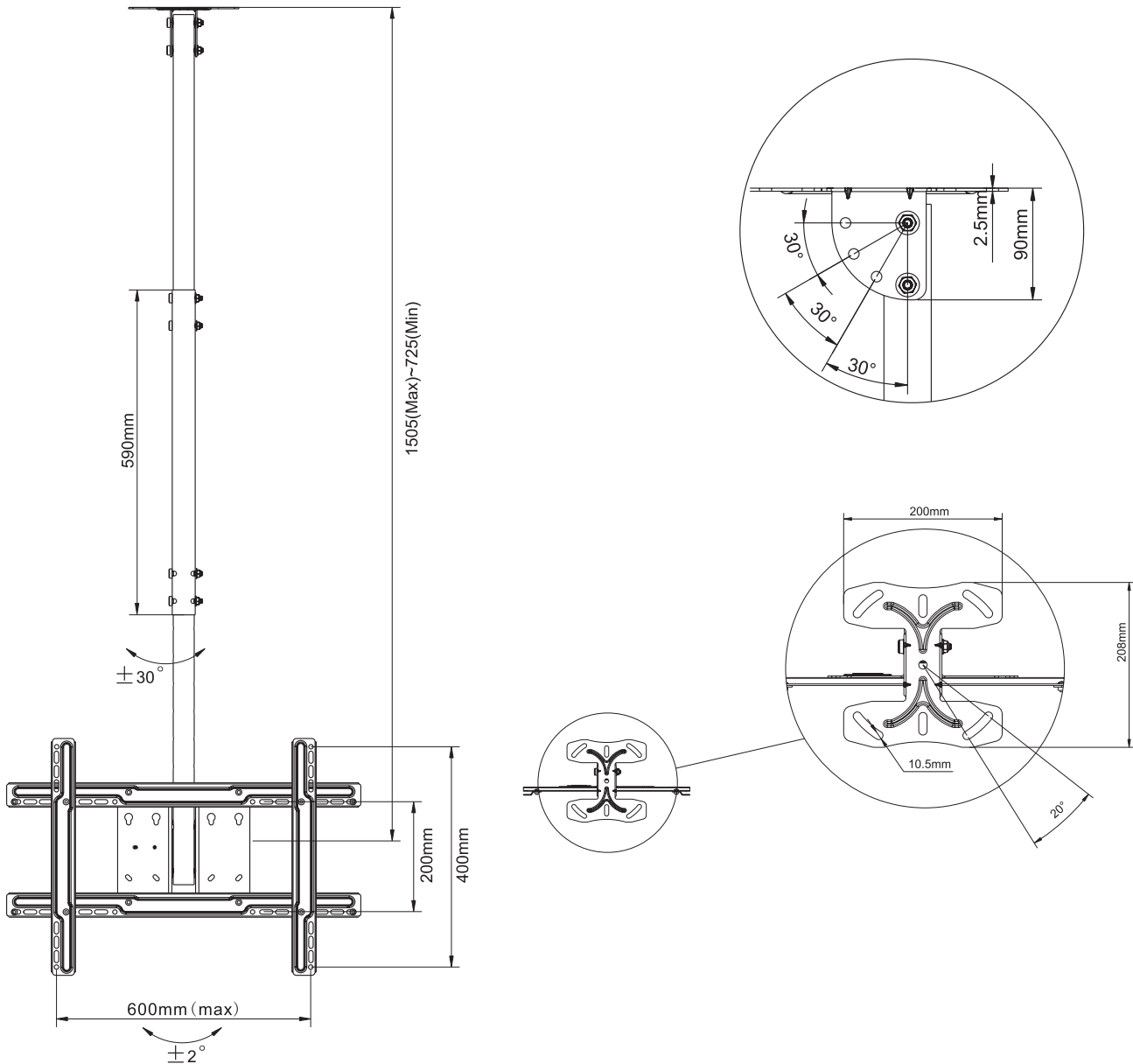

Notes

Multifunctional wall mounts has been designed only for mounting onto a wall constructed of wood studs, masonry or solid concrete wall. For safe installation, the wall you are mounting to must support minimum 4 times the weight of the total projector or TV panel weight.

For more information, please visit: www.nbavmount.com